

**THE EFFECT OF RADIATION ON THE FLOW OF GAS AT A STRONG EXPLOSION
FOR CONSIDERABLE TIME PARAMETERS**

PMM Vol. 39, № 2, 1975, pp. 246-252

V. V. ALEKSANDROV and G. L. STENCHIKOV

(Moscow)

(Received March 19, 1974)

Conditions are derived under which either kinetic, Planck, or Rosseland flow patterns obtain at the center of a strong explosion. The method of matching asymptotic expansions for fairly considerable time parameters is used in the approximation of weak effect of radiation on the flow of a gray radiating-absorbing gas. An analytic solution is obtained for the Planck mode. Errors of the first approximations are analyzed. The flow of a viscous heat-conducting gas at a strong explosion and considerable time parameter was analyzed in [1]. Here a similar problem is considered in the case of an inviscid radiating-absorbing gas.

1. A strong explosion in a radiating nondissipating absorbing inviscid gray gas is considered. Dependence of the volume absorption coefficient κ on pressure p and density ρ is assumed to follow the power law $\kappa = c p^\alpha \rho^\beta$. The gas is assumed to be perfect and in local thermodynamic equilibrium with uniform initial density distribution $\rho = c_\rho$.

The problem contains constants E_0 , c , c_ρ and $a = \sigma R^{-4}$, where E_0 is the energy released at the explosion, and σ and R are the Stefan-Boltzman and the gas constants, respectively [2]. The dimensions of these constants are, respectively, $ML^{d-1}T^2$, ML^{-3} , $ML^{-3}T^5$ and $M^{-\alpha-\beta}T^{2\alpha}L^{\alpha+3\beta-1}$ where $d = 1, 2, 3$, respectively, for the plane, cylindrical, and spherical symmetry, and M , L and T denote mass, length, and time, respectively. As the units of length and time we select

$$l^\circ = a^{2/(5d)} c_\rho^{-7/(5d)} E^{1/d}, \quad t^\circ = a^{(d+2)/(5d)} c_\rho^{-(d+7)/(5d)} E^{1/d}$$

and define the dimensionless velocity v° , pressure p° , density ρ° , enthalpy h° , radiation intensity I° and the Lagrangian coordinate ψ° as follows:

$$v = (c_\rho / a)^{1/5} v^\circ, \quad p = c_\rho (c_\rho / a)^{2/5} p^\circ, \quad \rho = c_\rho \rho^\circ$$

$$h = (c_\rho / a)^{2/5} h^\circ, \quad I = a (c_\rho / a)^{2/5} I^\circ, \quad \psi = c_\rho (l^\circ)^d \psi^\circ$$

The Euler equation and the equations of state, continuity, particle trajectory, energy, and radiation transfer in that notation are

$$\frac{\partial v}{\partial t} + r^{d-1} \frac{\partial p}{\partial \psi} = 0, \quad p = \frac{\gamma-1}{\gamma} \rho h, \quad \rho r^{d-1} \frac{\partial r}{\partial \psi} = 1, \quad v = \frac{\partial r}{\partial t} \quad (1.1)$$

$$\rho \frac{\partial h}{\partial t} - \frac{\partial p}{\partial t} = 4\tau_0 p^\alpha \rho^\beta \left(\frac{1}{4} \int_{4\pi} I d\Omega - \frac{p^4}{\rho^4} \right)$$

$$\mu \frac{\partial I}{\partial r} + \frac{d-1}{r} \left[\frac{5-d}{d+1} (1-\mu^2) - (3-d)\mu^2 \right] \frac{\partial I}{\partial \mu} = \tau_0 p^\alpha \rho^\beta \left(\frac{p^4}{\rho^4} - I \right)$$

$$\tau_0 = c c_\rho^{7(\alpha-1/d)/5+\beta} a^{-2(\alpha-1/d)/5} E^{1/d}$$

where r is the distance from the plane ($d = 1$), from the axis ($d = 2$), or from the center ($d = 3$) of symmetry, and γ is the adiabatic exponent. The radiation intensity I depends on coordinate r , time t , and the unit vector Ω of the direction of photon flight. The latter dependence can be defined in the plane and the spherical cases by the cosine of angle μ between the direction of the r -axis and vector Ω . In the case of cylindrical symmetry it is necessary to supplement it by the dependence on the cosine of angle μ_1 between Ω and the axis of symmetry. The quantity τ_0 is the characteristic optical thickness of the problem, and energy E is proportional to the explosion energy E_0 [1]. The superscript \circ is omitted throughout.

2. Let us consider the solution of problem (1.1) for a fairly great time parameter, when the effect of radiation on the motion of the medium can be considered weak everywhere, except at the small neighborhood of the center. The asymptotic behavior of a nonradiating gas flow is defined in that neighborhood by [1]

$$\begin{aligned} r &= a_0 Y_{00} t^{2k/d} n^l, \quad v = \frac{4a_0 V_{00}}{(2+d)(\gamma+1)} t^{-k} n^l \\ p &= \frac{8a_0^2 P_{00}}{(2+d)^2(\gamma+1)} t^{-2k}, \quad \rho = \frac{\gamma+1}{\gamma-1} R_{00} n^{1/\gamma} \\ h &= \frac{8a_0^2 \gamma H_{00}}{(2+d)^2(\gamma+1)^2} t^{-2k} n^{-1/\gamma}, \quad n = da_0^{-d} t^{-2k} \psi \rightarrow 0 \\ k &= d/(2+d), \quad l = (\gamma-1)/\gamma d \end{aligned} \quad (2.1)$$

where constants a_0 , Y_{00} , \dots and H_{00} are taken from the exact solution of L. I. Sedov.

We introduce the inner variable

$$N = d^{-1} a_0^2 n t^\delta = \psi t^{\delta-2dk} \quad (2.2)$$

The quantity δ is determined below with the use of the condition of equality of convective and radiation fluxes in the neighborhood of the center. It must satisfy the following two inequalities:

$$0 < \delta < 2d/(2+d). \quad (2.3)$$

The left-hand inequality implies that in the course of time the inhomogeneity of solution becomes localized in the neighborhood of the center, while the right-hand one is equivalent to stipulation for the inhomogeneity region in Lagrangian coordinates to widen with time because of radiation.

It follows from (2.1) and (2.2) that in the inner region it is necessary to seek a solution of the asymptotic form

$$\begin{aligned} r &= t^{2k/d-\delta l} y_i(N), \quad v = t^{-k-\delta l} v_i(N) \\ p &= t^{-2k} p_i(N), \quad \rho = t^{-\delta/\gamma} \rho_i(N) \\ h &= t^{-2k+\delta/\gamma} h_i(N), \quad I = t^{-8k+4\delta/\gamma} I_i(N, \Omega) \end{aligned} \quad (2.4)$$

At the center

$$y_i(0) = v_i(0) = 0, \quad I_i(0, \Omega) = I_i(0, -\Omega) \quad (2.5)$$

The requirement for matching the inner and outer solutions together with (2.1) and (2.4) imply that

$$\begin{aligned}
 y_i &\rightarrow a_0 Y_{00} \left(\frac{d}{a_0^d} N \right)^l, & v_i &\rightarrow \frac{4a_0 V_{00}}{(2+d)(\gamma+1)} \left(\frac{d}{a_0^d} N \right)^l & (2.6) \\
 p_i &\rightarrow \frac{8a_0^2}{(2+d)^2(\gamma+1)} P_{00}, & \rho_i &\rightarrow \frac{\gamma+1}{\gamma-1} R_{00} \left(\frac{d}{a_0^d} N \right)^{1/\gamma} \\
 h_i &\rightarrow \frac{8a_0^2 \gamma}{(2+d)^2(\gamma+1)^2} H_{00} \left(\frac{d}{a_0^d} N \right)^{-1/\gamma} & & \text{at } N \rightarrow \infty
 \end{aligned}$$

The first approximation of Eqs. (1.1) in variables (2.2) and (2.4) yields for the neighborhood center the asymptotic equations

$$p_i' = 0, \quad p_i = \frac{\gamma-1}{\gamma} \rho_i h_i \quad (2.7)$$

$$\rho_i y_i^{d-1} y_i' = 1 \quad (2.8)$$

$$v_i = \left(\frac{2}{2+d} - \delta \frac{\gamma-1}{\gamma d} \right) y_i + \left(\delta - \frac{2d}{2+d} \right) N y_i' \quad (2.9)$$

$$\left(\frac{2d}{2+d} - \delta \right) \left(N \frac{\rho_i'}{\rho_i} - \frac{1}{\gamma} \right) = \quad (2.10)$$

$$4t^{\delta_E} \frac{\gamma-1}{\gamma} \tau_0 p_i^{\alpha-1} \rho_i^\beta \left(\frac{1}{4} \int_{4\pi} I_i d\Omega - \frac{p_i^4}{\rho_i^4} \right)$$

$$\delta_E = \left(\frac{2+3d}{2+d} - \frac{2d}{2+d} (\alpha+4) \right) - \frac{\delta}{\gamma} (\beta-4)$$

$$\mu \frac{\partial I_i}{\partial y_i} + \frac{d-1}{y_i} \left[\frac{5-d}{d+1} (1-\mu^2) - (\beta-d) \mu^2 \right] \frac{\partial I_i}{\partial \mu} = \quad (2.11)$$

$$t^{\delta_\tau} \tau_0 p_i^\alpha \rho_i^\beta \left(\frac{p_i^4}{\pi \rho_i^4} - I_i \right)$$

$$\delta_\tau = \frac{2d}{2+d} \left(\frac{1}{d} - \alpha \right) - \frac{\delta}{\gamma} \left(\beta + \frac{\gamma-1}{d} \right)$$

where the prime denotes derivatives with respect to N .

The equation of motion (2.7) implies that in the neighborhood of the center the flow is isobaric with the pressure determined by the matching condition (2.6)

$$p_i = \frac{8a_0^2}{(2+d)^2(\gamma+1)} P_{00} \quad (2.12)$$

The availability of the integral (2.12) reduces the problem to the joint solution of the equations of energy (2.10) and of transfer (2.11) for functions ρ_i and I_i .

If the right-hand inequality (2.3) is not satisfied, the meaning of terms in the right-hand part of (2.10) which define the absorption and emission of heat is reversed, which is physically irrelevant.

3. The equation of transfer (2.11) implies that for considerable values of time the optical thickness of the inhomogeneity for

$$\delta_\tau = 0 \quad (3.1)$$

is of the order of τ_0 .

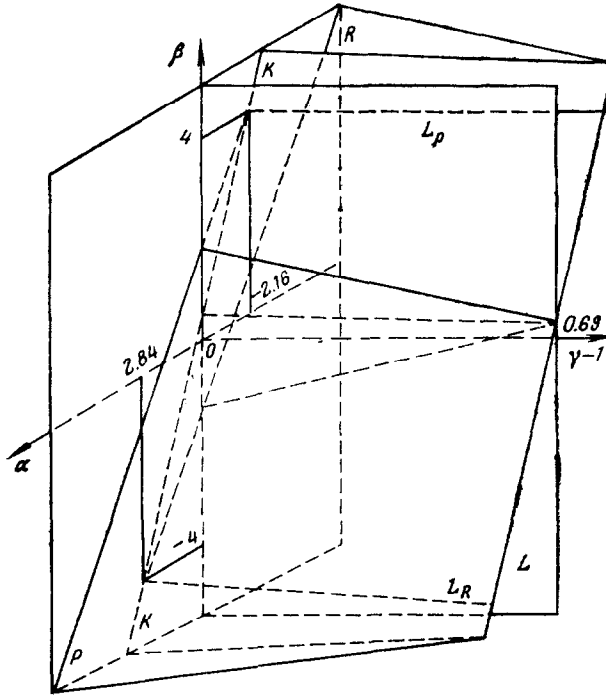

Fig. 1

This is the kinetic mode of radiation transfer. The right-hand part of the equation of energy remains of the form (2.10). The magnitude of the inhomogeneity region

$$\delta = \delta_K = \frac{2d}{2+d} \gamma \frac{1/d - \alpha}{\beta + (\gamma-1)/d} \tag{3.2}$$

determined by (3.1) must satisfy the additional condition

$$\delta_E = 0 \tag{3.3}$$

which follows from the equation of energy (2.10). Equality (3.3) together with (3.2) determine in space $\alpha \beta \gamma$ surface K which is a hyperbolic paraboloid

$$2 \alpha (\gamma - 1) d + 8 \alpha d^2 + 5 \beta d^2 + (5 d - 2) (\gamma - 1) - 8 d = 0$$

The inequalities (2.3) which bound δ_K impose on the adiabatic exponent the additional restriction

$$\gamma < \gamma_{\max} = 2 (4 d - 1) / (5 d - 2) \tag{3.4}$$

The part of surface K bounded by the plane $\gamma = 1$ and the straight line L of intersection of K with the plane $\gamma = \gamma_{\max}$ is shown in Fig. 1 for $d = 3$. If

$$\delta_\tau < 0 \tag{3.5}$$

the center optical thickness is small, and the emanation of radiant heat takes place in the Planck mode of volume luminescence denoted as the P -mode. The first term in the right-hand part of Eq. (2.10) which defines absorption is small in comparison with the second which defines photon emission.

The quantity $\delta = \delta_P$ determined by condition (3.3) is

$$\delta_P = \frac{2d}{2+d} \frac{\gamma}{\beta-4} \left(\frac{2-5d}{2d} - \alpha \right) \tag{3.6}$$

In the P -mode the equation of energy (2.10) is separated from the equation of transfer (2.11). With allowance for (3.6) it is of the form

$$\frac{1}{\gamma} - N \frac{\rho_i'}{\rho_i} = c_P \rho_i^{\beta-4} \tag{3.7}$$

$$c_P = 4 \frac{\gamma-1}{\gamma} \left(\frac{2d}{2+d} - \delta_P \right)^{-1} \tau_0 \rho_i^{\alpha+3}$$

Equation (3.7) together with condition (2.6) of merging for ρ_i has function

$$\rho_i = \left\{ \gamma c_P + \left[\frac{\gamma+1}{\gamma-1} R_{00} \left(\frac{d}{a_0^d} N \right)^{1/\gamma} \right]^{4-\beta} \right\}^{1/(4-\beta)} \tag{3.8}$$

as its solution if

$$\beta < \beta_P = 4 \tag{3.9}$$

Inequalities (2.3), (3.5) and (3.9) define in the $(\alpha \beta \gamma)$ -space the region of the P -mode. It is bounded from below by surface K and from above by the hyperbolic paraboloid P

$$\beta = \gamma \left(\frac{2-5d}{2d} - \alpha \right) + \beta_P$$

Surface P intersects surface K along the straight lines L and L_P with $\beta = 4$ and $\alpha = -(5d-2)/(2d)$. If

$$\delta_\tau > 0 \tag{3.10}$$

the center optical thickness is considerable and the transfer of radiation energy takes place in the Rosseland mode of radiation thermal conductivity, denoted the R -mode. The equation of energy (2.10) is again separated from the equation of transfer

$$\frac{1}{\gamma} - N \frac{\rho_i'}{\rho_i} = c_R t^{\delta_E - 2\delta_\tau} \rho_i [y_i^{2(d-1)} \rho_i^{-4-\beta} \rho_i']' \tag{3.11}$$

$$c_R = \frac{16}{3} \frac{\gamma-1}{\gamma} \frac{1}{\tau_0} \left(\frac{2d}{2+d} - \delta_R \right)^{-1} P_i^{3-\alpha}$$

The quantity

$$\delta = \delta_R = \frac{2d}{2+d} \gamma \frac{(2+5d)/(2d) - \alpha}{\beta+4+2(\gamma-1)/d} \tag{3.12}$$

is determined in accordance with (3.11) by the equation $\delta_E - 2\delta_\tau = 0$. Radiation intensity in the R -mode coincides in the first approximation with its equilibrium value, hence at the center

$$\rho_i'(0) = 0 \tag{3.13}$$

We introduce function $z = y_i^d$. The equation of continuity (2.8) implies that

$$\rho_i = d / z' \tag{3.14}$$

Substituting (3.14) into (3.11) and integrating once with allowance for (3.13), we obtain equation

$$z^m z'^{\beta+2z''} + A \left(Nz' - \frac{\gamma-1}{\gamma} z \right) = 0, \quad A = \frac{d^{2+\beta}}{c_R}, \quad m = \frac{2(d-1)}{d} \tag{3.15}$$

Boundary conditions for (3.15) are determined by (2.6) and the condition for the geometric coordinate to be zero at the center

$$N \rightarrow \infty : z \rightarrow a_0^d Y_{00}^d (da_0^{-d} N)^{(\gamma-1)/\gamma} \quad (3.16)$$

$$N = 0 : z = 0$$

The behavior of function z defined by (3.16) is governed at considerable N by the last two terms of Eq. (3.15). Hence for $N \rightarrow \infty$ it is necessary to specify that the first term of Eq. (3.15) on the asymptotics (3.16) must be small. This is possible for

$$\beta > \beta_R = -4 - 2(\gamma - 1) / d \quad (3.17)$$

Inequalities (2.3), (3.10), and (3.17) define the R -mode region in Fig. 1. It is bounded from above by surface K and from below by the hyperbolic paraboloid R

$$\beta = \beta_R + \gamma \left(\frac{2 + 5d}{2d} - \alpha \right)$$

Surface R intersects surface K along straight lines L and L_R with $\beta = \beta_R$ and $\alpha = (2 + 5d) / (2d)$.

For $\beta = -2$ (3.15) coincides with the equation derived in [1] in the analysis of a similar flow in a nonradiating gas whose viscosity and thermal conductivity are linearly dependent on temperature.

We point out once again that the plane, Planck and Rosseland modes obtain only at fairly small values of the adiabatic exponent defined by (3.4).

4. Let us indicate the accuracy of derived solutions. The error of the external solution can be estimated by two methods. In the first method we estimate the accuracy with which Eqs. (1.1) are satisfied in the Sedov solution. In the second method we estimate the accuracy of gas energy conservation in the perturbed volume, except in the neighborhood of the center. The energy balance must be taken into consideration, since the external solution used here satisfies the law of total energy conservation [1].

For considerable time parameters, the optical thickness $\tau_0 p^\alpha \rho^\beta$ of the external flow is proportional to $t^{-2\alpha d / (2+d)}$. For $\alpha > 0$ the radiation transfer in the external region takes place in the P -mode, for $\alpha = 0$ in the K -mode, and for $\alpha < 0$ in the R -mode. In the case of the first two modes the ratio of the right-hand part of the equation of energy (1.1) to its left-hand part is of the order of $O(t^{-\chi_K})$, while in the Rosseland mode it is of the order of $O(t^{-\chi_R})$, where

$$\chi_K = \frac{2d}{2+d} \left(\frac{5d-2}{2d} + \alpha \right) > 0, \quad \alpha \geq 0$$

$$\chi_R = \frac{2d}{2+d} \left(\frac{5d+2}{2d} - \alpha \right) > 0, \quad \alpha < 0$$

The computation error of the energy integral is of the order of $O(t^{-\delta(\gamma-1)/\gamma})$, [1].

It can be seen from Fig. 1 that for $\alpha \geq 0$ any of the three modes is possible in the neighborhood of the center. Hence the error of the external solution for $\alpha \geq 0$ is of the order of $O(t^{-\zeta_K})$, where $\zeta_K = \min[\chi_K, \delta(\gamma-1)/\gamma]$, and δ is defined by one of formulas (3.2), (3.6), or (3.12), depending on the pattern of flow in the neighborhood of the center. For $\alpha < 0$ the corresponding error is of the order of $O(t^{-\zeta_R})$, where $\zeta_R = \min[\chi_R, \delta(\gamma-1)/\gamma]$, and δ is equal δ_K , δ_P or δ_R , since for $\alpha < 0$ any of the three modes is possible at the center.

Let us now estimate the error of determination of flow in the neighborhood of the

center. Since the exactness of asymptotic formulas (2.1) is of the order of $O(n^{\zeta_i})$, where $\zeta_i = (\gamma - 1) / (\gamma d)$ the accuracy of formulas (2.4) is of the order of $O(t^{-\delta\zeta_i})$. The Euler equation (2.7) is derived from (1.1) and (2.4) with an accuracy of the order of $O(t^{-\delta\zeta_E})$, where $\zeta_E = (2\gamma + d - 2) / (\gamma d)$. There are no further simplifications in the kinetic mode. Hence, Eqs. (2.10) and (2.11) define the K -mode in the neighborhood of the center with an accuracy of the order of $O(t^{-\lambda_K})$, where $\lambda_K = \min(\delta_K \zeta_i, \zeta_E \delta_K)$.

In the Planck-mode Eq. (2.10) is approximated by (3.7) with an accuracy of the order of $O(t^{\delta\tau} \ln t^{-\delta\tau})$. Hence solution (3.8) defines such flow with an accuracy of the order of

$$O\{\min[t^{-\delta_P \zeta_i}, t^{-\delta_P \zeta_E}, t^{\delta\tau(\delta_P)} \ln t^{-\delta\tau(\delta_P)}]\}$$

The reduction of (2.10) to (3.11) is achieved in the R -mode with an error of the order of $O(t^{-2\delta\tau})$. The resulting error of determination of such flows is of the order of

$$O(t^{-\lambda_R}), \lambda_R = \min[\delta_R \zeta_i, \delta_R \zeta_E, 2\delta\tau(\delta_R)]$$

REFERENCES

1. Sychev, V. V., On the theory of strong explosion in a heat-conducting gas. PMM Vol. 29, № 6, 1965.
2. Aleksandrov, V. V., On a particular class of self-similar flows of a radiating gas. Izv. Akad. Nauk SSSR, MZhG, № 4, 1970.

Translated by J. J. D.

UDC 534.222.2

METHOD OF SOLUTION OF CERTAIN BOUNDARY VALUE PROBLEMS FOR HYPERBOLIC SYSTEMS OF QUASILINEAR EQUATIONS OF FIRST ORDER WITH TWO VARIABLES

PMM Vol. 39, № 2, 1975, pp. 253-259

M. Iu. KOZMANOV

(Cheliabinsk)

(Received March 6, 1974)

We propose a method of obtaining exact solutions of certain boundary value problems for hyperbolic systems of quasilinear equations of first order with two unknowns. The method utilizes special series. As an example, we solve the problem of motion of a plane, cylindrical or spherical piston in a gas with distributed density.

1. Let us consider the following system of equations:

$$A(x, \mathbf{U}) \frac{\partial \mathbf{U}}{\partial t} + B(x, \mathbf{U}) \frac{\partial \mathbf{U}}{\partial x} + C(x, \mathbf{U}) = 0 \quad (1.1)$$

$$\mathbf{U} = \{u_i(x, t)\}, \quad A(x, \mathbf{U}) = \{a_{ij}(x, \mathbf{U})\}, \quad B(x, \mathbf{U}) = \{b_{ij}(x, \mathbf{U})\}$$

$$C(x, \mathbf{U}) = \{c_i(x, \mathbf{U})\}, \quad i, j = 1, \dots, m$$